

Product Data Sheet



Product Code:	Issue No.	Issue Date:	Issue by:
MCP52/I250S	A	18/06/2015	A.R.

Description

5 Way TP mccb distribution board c/w 250A TP switch disconnecter incomer.

General Characteristics

Standards.	BS EN 61439-1&2
Current rating.	250A max incomer.
Voltage rating.	400V a.c.
Fault current rating.	36kA Icc.
Enclosure.	1.6mm cold rolled steel with an epoxy paint finish to RAL7035 matt grey. Bolted construction giving Form2B type 2 & Form3B type 2 group mounted segregation to BS EN 61439:Pt1 & 2:2011
IP Rating.	IP 3X
Pollution degree.	3
No of poles.	3 + neutral
Incomer terminal capacity.	Tunnel terminal 120mm sq cable max, Neutral M8 Bolt, Earth M10 Bolt.
Incomer terminal tightening torque.	MCCB 6 Nm, M8 Bolt 20Nm max, M10 Bolt 40Nm max.
Cable entry facility.	Top & bottom endplates removable for ease of cutting.
Covers / Door.	Screw fixed covers. Side hinged door (removable) c/w plastic turn catches.
No of Outgoing TP ways.	5
Equipment type.	Fixed stationary
Weight.	40.82kg



Switchgear Fitted

Device	Rating
TP Switch disconnecter incomer	250A

General Device Specification – Outgoing Switchgear ordered separately

MCCB:	16 to 250A TP 36kA 400V AC Terminal capacity 120mm sq. BS EN 60947-2 16 to 200A SP 36kA 230V AC Terminal capacity 120mm sq. BS EN 60947-2 Please refer to Device data sheet for further information.
--------------	--

Product Data Sheet



Product Code: MCP52/I250S	Issue No. A	Issue Date: 18/06/2015	Issue by: A.R.
-------------------------------------	-----------------------	----------------------------------	--------------------------

Description

5 Way TP mccb distribution board c/w 250A TP switch disconnect incomer.

Key Dimensions

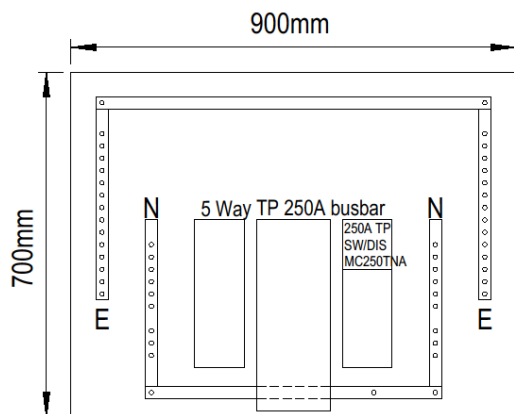

Mounting hole positions

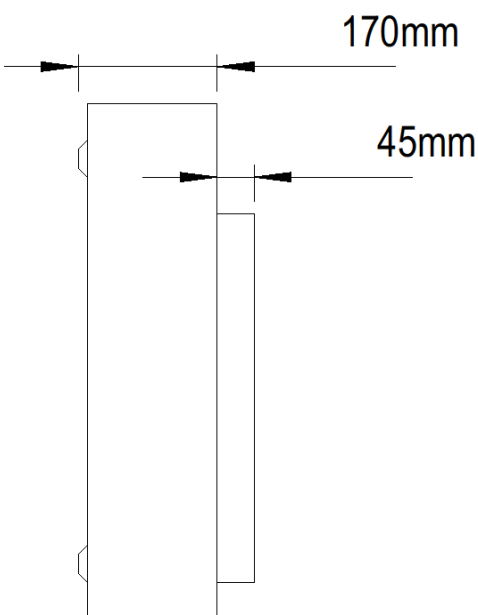
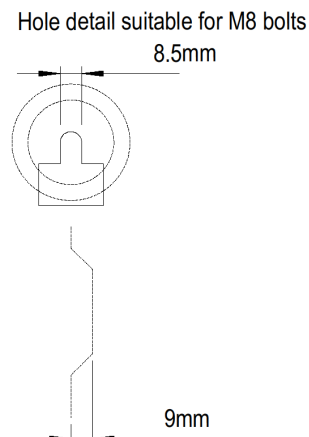
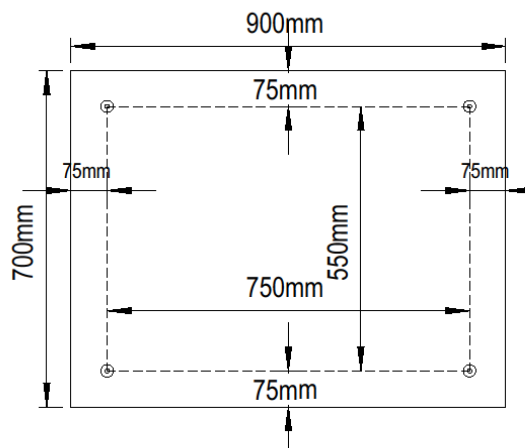

Additional information.

Usage

Intended for use by skilled persons or instructed persons.

Electrical

Earth & Neutral terminals M8 bolts – tightening torque 20Nm max.

Rated frequency: 50Hz.

Rated operational voltage: 230/400V a.c.

Rated insulation voltage: 690V a.c.

Earthing system: Suitable for use with TN-S, TN-C-S and TT systems.

EMC environment: Environment type A.

Physical

Ambient operating temperature -5 to 40 °C

(Not exceeding average of 35 °C in any 24 hour period).

Maximum altitude 2000m.

Enclosure: Enclosed assembly galvanised base and internal steel work, external steel work (sides, end, covers and doors) powder coated in hardwearing epoxy matt light grey paint to RAL 7035.

Installation

Service conditions: Wiring of this product must comply with current IEE regulations. Units are intended for indoor use and dry conditions and **NOT** where high levels of humidity and temperature are experienced.

Note: IP rating of enclosures can be compromised if correct use of glands is not followed when installing unit.