

# Product Data Sheet



Product Code: <b>MCEL400F</b>	Issue No. <b>B</b>	Issue Date: 10 /12 /2018	Issue by: T. Tombs
-------------------------------	-----------------------	-----------------------------	-----------------------

## Description

400A 4P MCCB with bolted neutral link.  
Type A filtered earth leakage relay, voltage dependent, mounted in a mild steel enclosure.

## General Characteristics

Standards.	BS EN60947-1 & 2. IEC 60755, IEC 62020, IEC 61543.
Current rating.	400A
Voltage rating.	230 / 400V ac. 50/60Hz.
Fault current rating	36kA.
Enclosure. Dimensions	Mild steel to IP3X. 950mmH x 400mmW x 170mmD.
Finish	Matt grey to RAL 7035, Electrostatically applied.
IP Rating.	3X
No of poles.	4 switched.
Terminal capacity.	Phases – M12 bolt. Neutral – M12 bolt.
Terminal tightening torque.	Mccb – 50Nm. Neutral – 50Nm.
Cable entry facility.	Plain plate top and bottom. Drill to suit on site.
Covers / Door.	Front bolt on cover.
Earth leakage relay settings. True RMS sensing. Adjustable.	Milli amp – 30, 100, 300, 500. Amps – 1, 3, 5, 10, 20, 30.  Time – mS 0, 60, 150, 250, 500, 800. Sec – 1, 2.5, 5, 10.
E/L CT diameter.	120mm internal diameter.
Equipment type.	Fixed stationary
Weight.	29 kg



Switchgear Fitted	
Device	Rating
MC400FA Earth Leakage relay and CT	400A

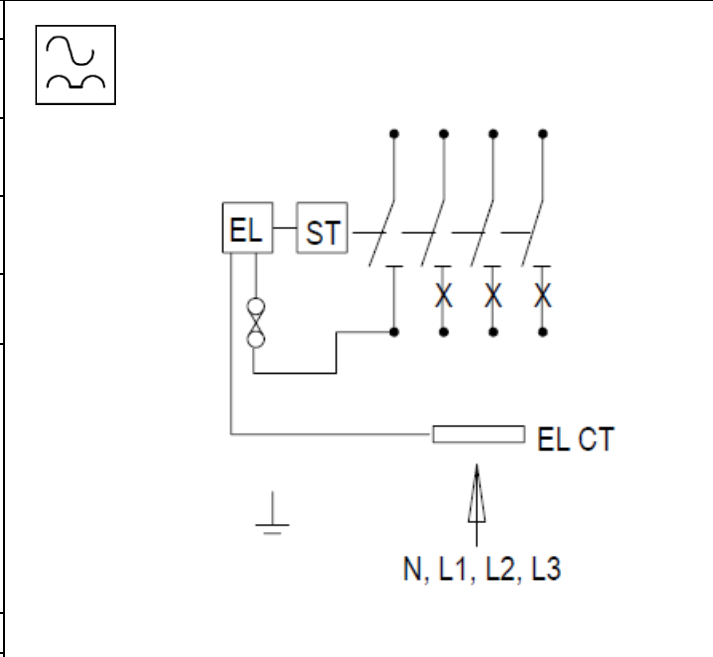

Minimum sensitivity  $I_{\Delta n} - 0.1 A$   
It is intended that this device is under the supervision of an instructed or skilled person.  
BS7671:2018 clause 531.3.4.2

<b>MCCB:</b>	For full technical details of the mccb request MCCB data sheet.
<b>Accessories.</b>	Padlock device: Part no. <b>MCPD</b> (padlock not supplied).

# Product Data Sheet



Product Code: <b>MCEL400F</b>	Issue No. <b>B</b>	Issue Date: 10 /12 /2018	Issue by: T. Tombs
-------------------------------	-----------------------	-----------------------------	-----------------------

**Description**  
 400A 4P MCCB with bolted neutral link.  
 Type A filtered earth leakage relay, voltage dependent, mounted in a mild steel enclosure.

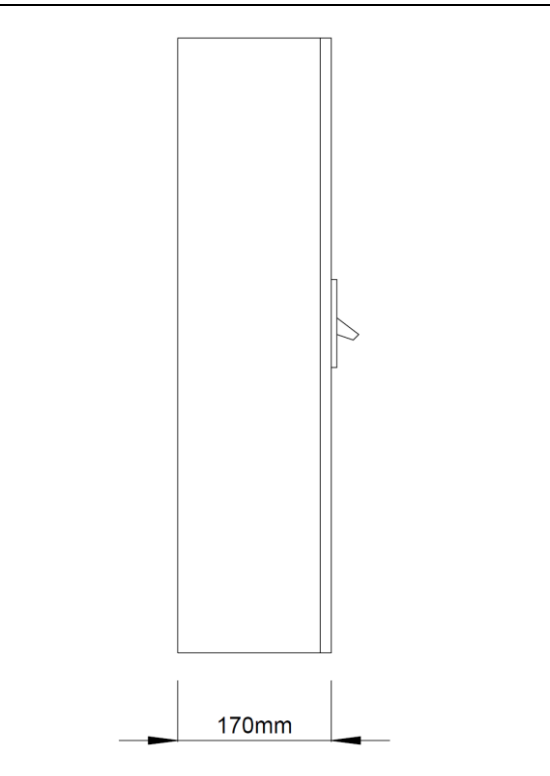
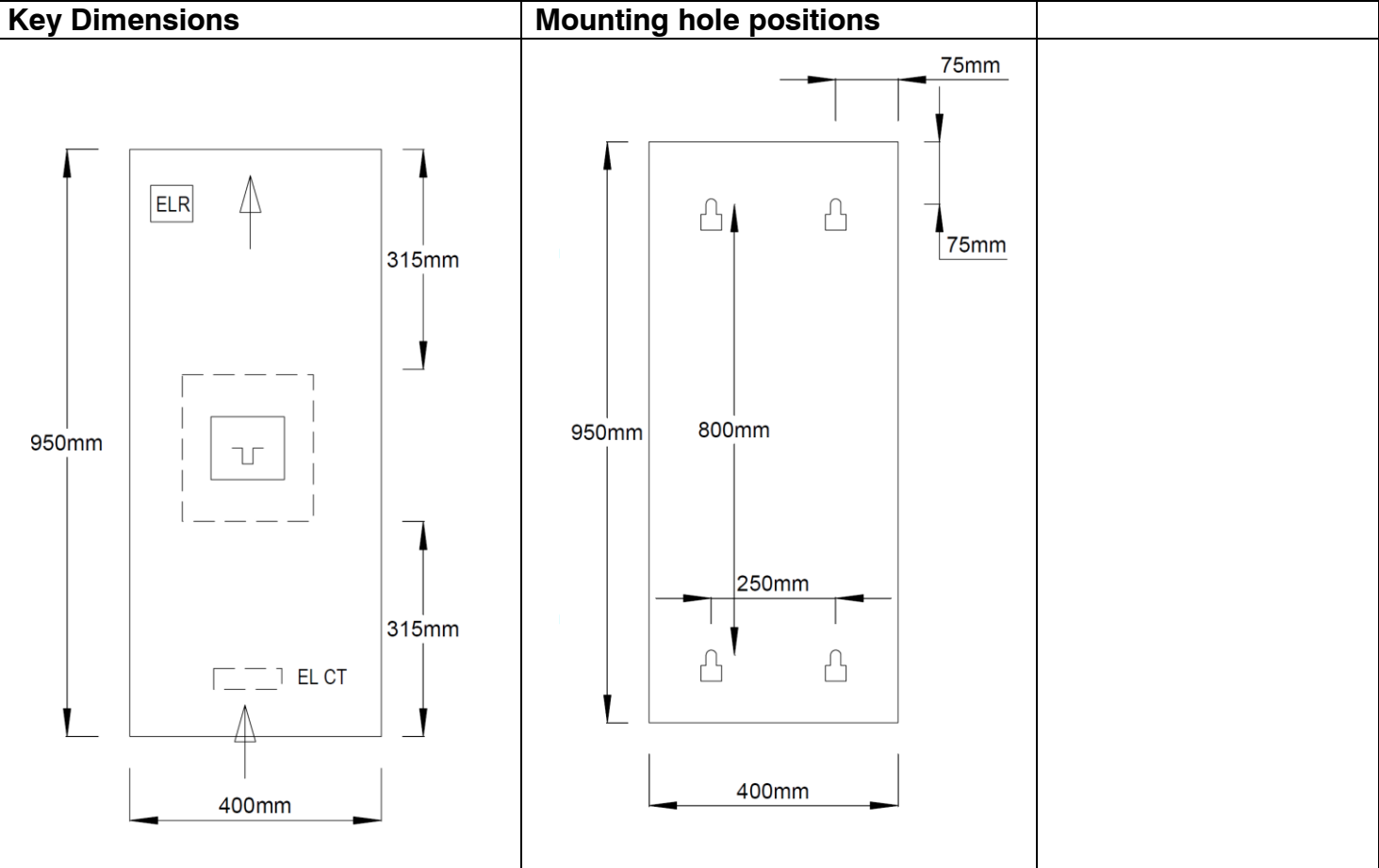

**Additional information.**

**Usage**  
 Intended for use by skilled persons or instructed persons.

**Electrical**  
 Earth terminal : Earth bolt M10.  
 Rated frequency: 50Hz.  
 Rated operational voltage: 400V  
 Rated insulation voltage: 750V.  
 Earthing system:  
 EMC environment: Environment type A.

**Physical**  
 Ambient operating temperature -5 to 40 °C  
 (Not exceeding average of 35 °C in any 24 hour period).  
 Maximum altitude 2000m.

**Earth Leakage relay**  
 Power on LED.  
 Earth leakage indication displayed in LED array (% leakage of setting).

**Installation**  
 Service conditions: Wiring of this product must comply with current IEE regulations. Units are intended for indoor use and dry conditions and **NOT** where high levels of humidity and temperature are experienced.  
 Note: IP rating of enclosures can be compromised if correct use of glands is not followed when installing unit.