

Product datasheet

Specifications



variable speed drive, Altivar Process ATV600, ATV650, 45kW, 400 to 480V, IP55

ATV650D45N4

Main

| | |
|--|--|
| Range of product | Altivar Process ATV600 |
| Product specific application | Process and utilities |
| Product or component type | Variable speed drive |
| Variant | Standard version |
| Device short name | ATV650 |
| Mounting mode | Wall mount |
| Communication port protocol | Ethernet Modbus TCP Modbus TCP |
| [Us] rated supply voltage | 380...480 V - 15...10 % |
| [Us] rated supply voltage | 380...480 V |
| Relative symmetric mains voltage tolerance | 10 % |
| Relative symmetric network frequency tolerance | 5 % |
| nominal output current | 88.0 A |
| IP degree of protection | IP55 |
| Product destination | Asynchronous motors Synchronous motors |
| EMC filter | Integrated with 50 m conforming to IEC 61800-3 category C2 Integrated with 150 m conforming to IEC 61800-3 category C3 |
| IP degree of protection | IP55 conforming to IEC 60529 IP55 conforming to IEC 61800-5-1 |
| type of cooling | Forced convection |
| Supply frequency | 50...60 Hz - 5...5 % |
| Motor power kW | 37 kW (heavy duty) 45 kW (normal duty) |
| Motor power hp | 40 hp heavy duty 60 hp normal duty |
| Line current | 57.3 A at 480 V (normal duty) 54.8 A at 380 V (heavy duty) 48.3 A at 480 V (heavy duty) 79.8 A at 380 V (normal duty) |
| Continuous output current | 59 A at 4 kHz for heavy duty 87 A at 4 kHz for normal duty |
| Speed drive output frequency | 0.1...500 Hz |
| Safety function | STO (safe torque off) SIL 3 |

| | |
|--------------------|---|
| Option card | Slot A: communication module, PROFINET Slot A: communication module, DeviceNet Slot A: communication module, Modbus TCP/EtherNet/IP Slot A: communication module, CANopen daisy chain RJ45 Slot A: communication module, CANopen SUB-D 9 Slot A: communication module, CANopen screw terminals Slot A/slot B: digital and analog I/O extension module Slot A/slot B: output relay extension module Slot A: communication module, Ethernet IP/Modbus TCP/MD-Link Communication module, BACnet MS/TP Communication module, Ethernet Powerlink Slot A: communication module, Profibus DP V1 |
|--------------------|---|

Complementary

| | |
|--|--|
| Discrete input number | 8 |
| Discrete input type | DI7, DI8 programmable as pulse input: 0...30 kHz, 24 V DC (<= 30 V) |
| Discrete input logic | 16 preset speeds |
| Discrete output number | 0 |
| Discrete output type | Relay outputs R1A, R1B, R1C 250 V AC 3000 mA Relay outputs R1A, R1B, R1C 30 V DC 3000 mA Relay outputs R2A, R2C 250 V AC 5000 mA Relay outputs R2A, R2C 30 V DC 5000 mA Relay outputs R3A, R3C 250 V AC 5000 mA Relay outputs R3A, R3C 30 V DC 5000 mA |
| Analogue input number | 3 |
| Analogue input type | AI1, AI2, AI3 software-configurable voltage: 0...10 V DC, impedance: 31.5 kOhm, resolution 12 bits AI1, AI2, AI3 software-configurable current: 0...20 mA, impedance: 250 Ohm, resolution 12 bits AI2 voltage analog input: - 10...10 V DC, impedance: 31.5 kOhm, resolution 12 bits |
| Analogue output number | 2 |
| Analogue output type | Software-configurable voltage AQ1, AQ2: 0...10 V DC impedance 470 Ohm, resolution 10 bits Software-configurable current AQ1, AQ2: 0...20 mA, resolution 10 bits Software-configurable current DQ-, DQ+: 30 V DC Software-configurable current DQ-, DQ+: 100 mA |
| Relay output number | 3 |
| Relay output type | Configurable relay logic R2: sequence relay NO electrical durability 100000 cycles Configurable relay logic R3: sequence relay NO electrical durability 100000 cycles Configurable relay logic R1: fault relay NO/NC electrical durability 100000 cycles |
| Maximum switching current | Relay output R1, R2, R3 on resistive load, cos phi = 1: 3 A at 30 V DC Relay output R1, R2, R3 on inductive load, cos phi = 0.4 and L/R = 7 ms: 2 A at 250 V AC Relay output R1, R2, R3 on inductive load, cos phi = 0.4 and L/R = 7 ms: 2 A at 30 V DC Relay output R1, R2, R3 on resistive load, cos phi = 1: 3 A at 250 V AC |
| Minimum switching current | Relay output R1, R2, R3: 5 mA at 24 V DC |
| Network number of phases | 3 phases |
| Physical interface | Ethernet 2-wire RS 485 |
| Method of access | Slave Modbus TCP |
| Transmission rate | 10, 100 Mbits 4800 bps, 9600 bps, 19200 bps, 38.4 Kbps |
| Transmission frame | RTU |
| Output voltage | <= power supply voltage |
| Permissible temporary current boost | 1.5 x I _n during 60 s (heavy duty) 1.1 x I _n during 60 s (normal duty) |
| Data format | 8 bits, configurable odd, even or no parity |

| | |
|--|--|
| Type of polarization | No impedance |
| Frequency resolution | Analog input: 0.012/50 Hz Display unit: 0.1 Hz |
| Electrical connection | Line side: screw terminal 25...50 mm ² /AWG 4...AWG 1 Motor: screw terminal 35...50 mm ² /AWG 3...AWG 1 Control: removable screw terminals 0.5...1.5 mm ² /AWG 20...AWG 16 |
| Connector type | RJ45 (on the remote graphic terminal) for Modbus serial RJ45 (on the remote graphic terminal) for Ethernet/Modbus TCP |
| Exchange mode | Half duplex, full duplex, autonegotiation Ethernet/Modbus TCP |
| Number of addresses | 1...247 for Modbus serial |
| Supply | Internal supply for reference potentiometer (1 to 10 kOhm): 10.5 V DC +/- 5 %, <10 mA, protection type: overload and short-circuit protection Internal supply for digital inputs and STO: 24 V DC (21...27 V), <200 mA, protection type: overload and short-circuit protection External supply for digital inputs: 24 V DC (19...30 V), <1.25 mA, protection type: overload and short-circuit protection |
| Local signalling | 3 LEDs (dual colour) for embedded communication status 4 LEDs (dual colour) for communication module status 1 LED (red) for presence of voltage 3 LEDs for local diagnostic |
| Input compatibility | DI5, DI6: discrete input level 1 PLC conforming to IEC 65A-68 STOA, STOB: discrete input level 1 PLC conforming to IEC 61131-2 DI1...DI6: discrete input level 1 PLC conforming to IEC 61131-2 |
| Discrete input logic | Positive logic (source) (DI1...DI8), < 5 V (state 0), > 11 V (state 1) Negative logic (sink) (DI1...DI8), > 16 V (state 0), < 10 V (state 1) |
| Sampling duration | 5 ms +/- 1 ms (DI5, DI6) - discrete input 5 ms +/- 0.1 ms (AI1, AI2, AI3) - analog input 10 ms +/- 1 ms (AO1) - analog output 2 ms +/- 0.5 ms (DI1...DI4) - discrete input |
| Accuracy | +/- 1 % AO1, AO2 for a temperature variation 60 °C analog output +/- 0.6 % AI1, AI2, AI3 for a temperature variation 60 °C analog input |
| Linearity error | AO1, AO2: +/- 0.2 % for analog output AI1, AI2, AI3: +/- 0.15 % of maximum value for analog input |
| Refresh time | Relay output (R1, R2, R3): 5 ms (+/- 0.5 ms) |
| Isolation | Between power and control terminals |
| Discrete and process manufacturing | Building - HVAC compressor centrifugal |
| Power range | 30...50 kW at 380...440 V 3 phases |
| Enclosure mounting | Wall mounted |
| 4 quadrant operation possible | False |
| Asynchronous motor control profile | Optimized torque mode Constant torque standard Optimized torque mode |
| Synchronous motor control profile | Synchronous reluctance motor Permanent magnet motor |
| Maximum output frequency | 500 kHz |
| Acceleration and deceleration ramps | Linear adjustable separately from 0.01...9999 s |
| Motor slip compensation | Adjustable Automatic whatever the load Can be suppressed Not available in permanent magnet motor law |
| Switching frequency | 4...12 kHz with derating factor 2...12 kHz adjustable |
| Nominal switching frequency | 4 kHz |

| | |
|---|--|
| Braking to standstill | By DC injection |
| Brake chopper integrated | False |
| Maximum input current | 79.8 A |
| Maximum output voltage | 480.0 V |
| Apparent power | 40.2 kVA at 480 V (heavy duty) 57.4 kVA at 480 V (normal duty) |
| Maximum transient current | 92.3 A during 60 s (heavy duty) 96.8 A during 60 s (normal duty) |
| Network frequency | 50...60 Hz |
| Prospective line Isc | 50 kA |
| Base load current at high overload | 74.5 A |
| Base load current at low overload | 88.0 A |
| With safety function Safely Limited Speed (SLS) | False |
| With safety function Safe brake management (SBC/SBT) | False |
| With safety function Safe Operating Stop (SOS) | False |
| With safety function Safe Position (SP) | False |
| With safety function Safe programmable logic | False |
| With safety function Safe Speed Monitor (SSM) | False |
| With safety function Safe Stop 1 (SS1) | False |
| With sft fct Safe Stop 2 (SS2) | False |
| With safety function Safe torque off (STO) | True |
| With safety function Safely Limited Position (SLP) | False |
| With safety function Safe Direction (SDI) | False |
| Protection type | Safe torque off: motor Motor phase break: motor Thermal protection: drive Safe torque off: drive Overheating: drive Overcurrent between output phases and earth: drive Overload of output voltage: drive Short-circuit protection: drive Motor phase break: drive Overvoltages on the DC bus: drive Line supply overvoltage: drive Line supply undervoltage: drive Line supply phase loss: drive Overspeed: drive Break on the control circuit: drive Thermal protection: motor |
| Quantity per set | 1 |
| Width | 290 mm |
| Height | 910 mm |
| Depth | 340 mm |
| Product weight | 50 kg |

Environment

| | |
|------------------------------|---|
| Insulation resistance | > 1 MOhm 500 V DC for 1 minute to earth |
| Noise level | 69.7 dB conforming to 86/188/EEC |

| | |
|---|--|
| Pollution degree | 2 conforming to IEC 61800-5-1 |
| Vibration resistance | 1 gn (f= 13...200 Hz) conforming to IEC 60068-2-6 1.5 mm peak to peak (f= 2...13 Hz) conforming to IEC 60068-2-6 |
| Shock resistance | 15 gn for 11 ms conforming to IEC 60068-2-27 |
| Relative humidity | 5...95 % without condensation conforming to IEC 60068-2-3 |
| Ambient air temperature for operation | 40...50 °C (with derating factor) -15...40 °C (without derating) |
| Operating altitude | 1000...4800 m with current derating 1 % per 100 m <= 1000 m without derating |
| Operating position | Vertical +/- 10 degree |
| Product certifications | TÜV CSA UL ATEX INERIS Bureau Veritas DNV-GL CSA |
| Marking | CE |
| Standards | IEC 61800-3 IEC 61800-3 environment 1 category C2 EN/IEC 61800-3 environment 2 category C3 IEC 61800-5-1 IEC 61000-3-12 IEC 60721-3 IEC 61508 IEC 13849-1 UL 508C |
| Maximum THDI | <48 % from 80...100 % of load conforming to IEC 61000-3-12 |
| Electromagnetic compatibility | Radiated radio-frequency electromagnetic field immunity test level 3 conforming to IEC 61000-4-3 Electrical fast transient/burst immunity test level 4 conforming to IEC 61000-4-4 1.2/50 µs - 8/20 µs surge immunity test level 3 conforming to IEC 61000-4-5 Conducted radio-frequency immunity test level 3 conforming to IEC 61000-4-6 Electrostatic discharge immunity test level 3 conforming to IEC 61000-4-2 |
| Environmental class (during operation) | Class 3C3 according to IEC 60721-3-3 Class 3S3 according to IEC 60721-3-3 |
| Maximum acceleration under shock impact (during operation) | 150 m/s ² at 11 ms |
| Maximum acceleration under vibrational stress (during operation) | 10 m/s ² at 13...200 Hz |
| Maximum deflection under vibratory load (during operation) | 1.5 mm at 2...13 Hz |
| Permitted relative humidity (during operation) | Class 3K5 according to EN 60721-3 |
| Overvoltage category | III |
| Regulation loop | Adjustable PID regulator |
| Noise level | 69.7 dB |
| pollution degree | 3 |
| Ambient air transport temperature | -40...70 °C |
| Ambient air temperature for storage | -40...70 °C |

Packing Units

| | |
|-------------------------------------|-----------|
| Unit Type of Package 1 | PCE |
| Number of Units in Package 1 | 1 |
| Package 1 Height | 64.000 cm |

| | |
|-------------------------|------------|
| Package 1 Width | 43.000 cm |
| Package 1 Length | 112.000 cm |
| Package 1 Weight | 54.000 kg |



Environmental Data

Schneider Electric aims to achieve Net Zero status by 2050 through supply chain partnerships, lower impact materials, and circularity via our ongoing “Use Better, Use Longer, Use Again” campaign to extend product lifetimes and recyclability.

[Environmental Data explained >](#)

[How we assess product sustainability >](#)

Environmental footprint

Carbon footprint (kg.eq.CO2 per CR, Total Life cycle) **36373**

Environmental Disclosure [Product Environmental Profile](#)

Use Better

Materials and Substances

Packaging made with recycled cardboard **Yes**

Packaging without single use plastic **No**

[EU RoHS Directive](#) **Pro-active compliance (Product out of EU RoHS legal scope)**

SCIP Number **5fb596ba-e321-43d4-bd6d-9f75a221228c**

REACH Regulation [REACH Declaration](#)

Energy efficiency

Product contributes to saved and avoided emissions **Yes**

Use Again

Repack and remanufacture

Circularity Profile [End of Life Information](#)

Take-back **No**

WEEE  **The product must be disposed on European Union markets following specific waste collection and never end up in rubbish bins**

Dimensions Drawings

Dimensions

Front and Left Views

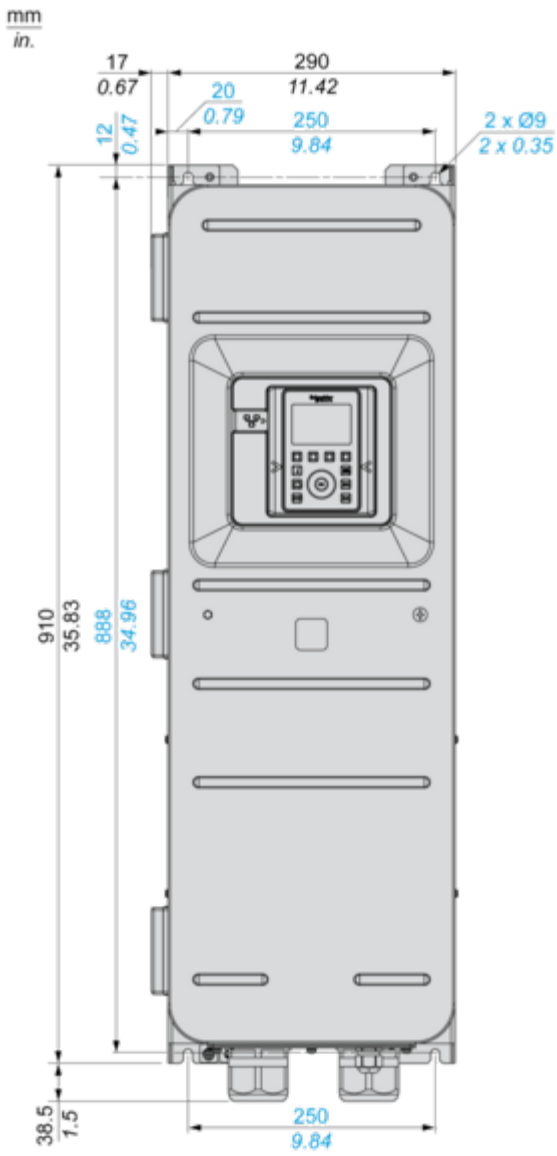

mm
in.

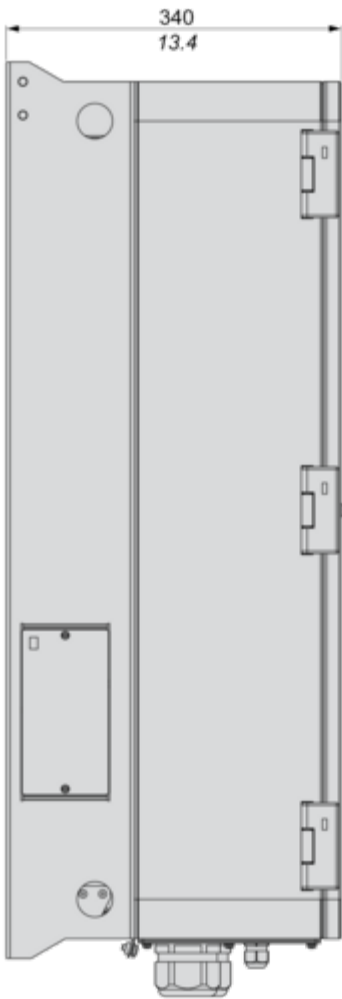

Mounting and Clearance

Clearances

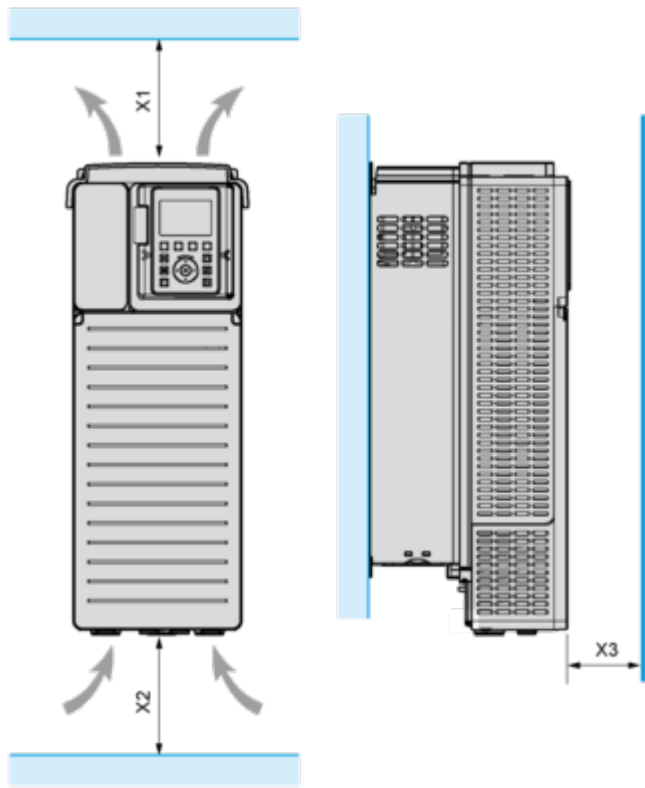

| X1 | X2 | X3 |
|---------------------|---------------------|--------------------|
| ≥ 100 mm (3.94 in.) | ≥ 100 mm (3.94 in.) | ≥ 10 mm (0.39 in.) |

Connections and Schema

Three-Phase Power Supply with Upstream Breaking via Line Contactor

Connection diagrams conforming to standards EN 954-1 category 1 and IEC/EN 61508 capacity SIL1, stopping category 0 in accordance with standard IEC/EN 60204-1



(1) Line choke if used

(2) Use relay R1 set to operating state Fault to switch Off the product once an error is detected.

A1 : Drive

KM1 : Line Contactor

Q2, Q3 : Circuit breakers

S1, S2 : Pushbuttons

T1 : Transformer for control part

Three-Phase Power Supply with Downstream Breaking via Contactor

Connection diagrams conforming to standards EN 954-1 category 1 and IEC/EN 61508 capacity SIL1, stopping category 0 in accordance with standard IEC/EN 60204-1

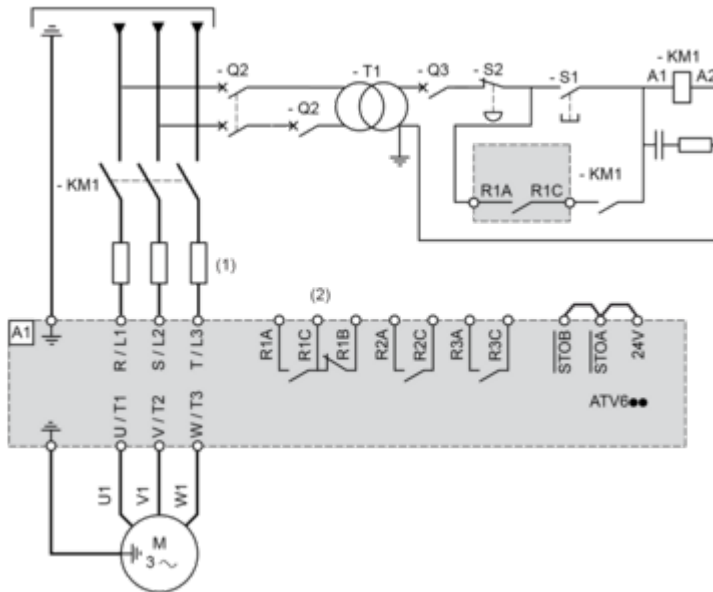

(1) Line choke if used

(2) Use relay R1 set to operating state Fault to switch Off the product once an error is detected.

A1 : Drive

KM1 : Contactor

Control Block Wiring Diagram



- (1) Safe Torque Off
- (2) Analog Output
- (3) Digital Input
- (4) Reference potentiometer
- (5) Analog Input
- R1A, R1B, R1C : Fault relay
- R2A, R2C : Sequence relay
- R3A, R3C : Sequence relay

Sensor Connection

It is possible to connect either 1 or 3 sensors on terminals AI2 or AI3.



Sink / Source Switch Configuration

The switch is used to adapt the operation of the logic inputs to the technology of the programmable controller outputs.

- Set the switch to Source (factory setting) if using PLC outputs with PNP transistors.
- Set the switch to Ext if using PLC outputs with NPN transistors.

Switch Set to SRC (Source) Position Using the Output Power Supply for the Digital Inputs

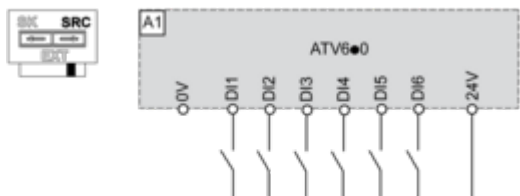

Switch Set to SRC (Source) Position and Use of an External Power Supply for the DIs

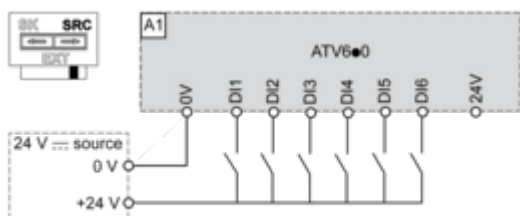

Switch Set to SK (Sink) Position Using the Output Power Supply for the Digital Inputs

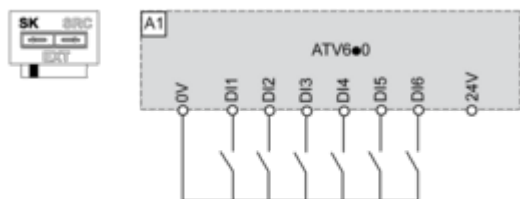

Switch Set to EXT Position Using an External Power Supply for the DIs

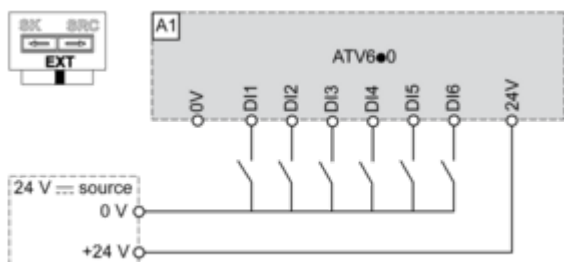

Performance Curves

Derating Curves

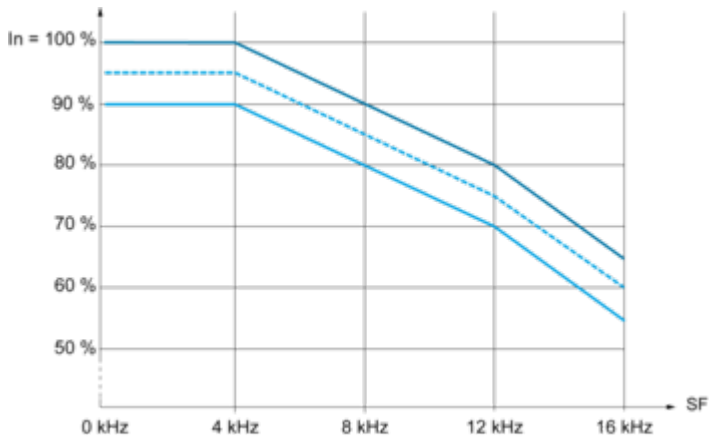

- 40 °C (104 °F)
 - ⋯ 45 °C (113 °F)
 - 50 °C (122 °F)
- In : Nominal Drive Current
SF : Switching Frequency