

Product datasheet

Specifications



Interface plug in relay, Harmony Electromechanical Relays, 10A, 1C/O, with LED, lockable test button, 24V DC

RXG12BD

Main

Range of product	Harmony Electromechanical Relays
Series name	Interface relay
Product or component type	Plug-in relay
Device short name	RXG
Contacts type and composition	1 C/O
[I _{th}] conventional enclosed thermal current	10 A at -40...55 °C
Local signalling	Flag

Complementary

[U _i] rated insulation voltage	250 V conforming to IEC 300 V conforming to CSA 300 V conforming to UL
Maximum switching voltage	250 V AC 30 V DC
Drop-out voltage threshold	$\geq 0.1 U_c$ DC
Load current	10 A at 250 V AC
Minimum switching capacity	500 mW at 100 mA, 5 V DC
Maximum switching capacity	2500 VA
Contact resistance	100 mOhm
Insulation resistance	1000 MOhm at 500 V DC
Electrical insulation class	Class F
Mechanical durability	10000000 cycles
Safety reliability data	B10d = 100000
Operating rate	≤ 1800 cycles/hour under load ≤ 18000 cycles/hour no-load
Utilisation coefficient	20 %
Operating time	20 ms
Reset time	20 ms
Dielectric strength	1000 V AC between contacts with micro disconnection 5000 V AC between coil and contact with reinforced insulation
Overvoltage category	III
Protection category	RT I
Pollution degree	2

Test levels	Level A group mounting
Device presentation	Complete product
Contacts material	Silver alloy (AgSnO2In2O3)
Net weight	0.02 kg

Environment

Standards	IEC 61810-1 CSA C22.2 No 14 UL 508
Product certifications	CSA CE EAC UL DNV-GL
Ambient air temperature for storage	-40...85 °C
Ambient air temperature for operation	-40...70 °C
IP degree of protection	IP40
Relative humidity	10...85 %
Vibration resistance	3 gn, amplitude = +/- 0.75 mm (f = 10...150 Hz)in operation 5 gn, amplitude = +/- 0.75 mm (f = 10...150 Hz)not in operation

Packing Units

Unit Type of Package 1	PCE
Number of Units in Package 1	1
Package 1 Height	2.89 cm
Package 1 Width	1.27 cm
Package 1 Length	3.452 cm
Package 1 Weight	20.87 g
Unit Type of Package 2	BB1
Number of Units in Package 2	10
Package 2 Height	3.45 cm
Package 2 Width	9.15 cm
Package 2 Length	8.2 cm
Package 2 Weight	408.7 g
Unit Type of Package 3	S01
Number of Units in Package 3	200
Package 3 Height	15 cm
Package 3 Width	15 cm
Package 3 Length	40 cm
Package 3 Weight	4.426 kg

Environmental Data

Schneider Electric aims to achieve Net Zero status by 2050 through supply chain partnerships, lower impact materials, and circularity via our ongoing “Use Better, Use Longer, Use Again” campaign to extend product lifetimes and recyclability.

[Environmental Data explained >](#)

[How we assess product sustainability >](#)

Environmental footprint

Carbon footprint (kg.eq.CO2 per CR, Total Life cycle)	10
---	-----------

Environmental Disclosure	Product Environmental Profile
--------------------------	---

Use Better

Materials and Substances

Packaging made with recycled cardboard	Yes
--	------------

Packaging without single use plastic	Yes
--------------------------------------	------------

EU RoHS Directive	Pro-active compliance (Product out of EU RoHS legal scope)
-----------------------------------	---

REACH Regulation	REACH Declaration
------------------	-----------------------------------

China RoHS Regulation	China RoHS declaration
-----------------------	--

Use Again

Repack and remanufacture

Circularity Profile	No need of specific recycling operations
---------------------	---

Take-back

No

Dimensions Drawings

Dimensions

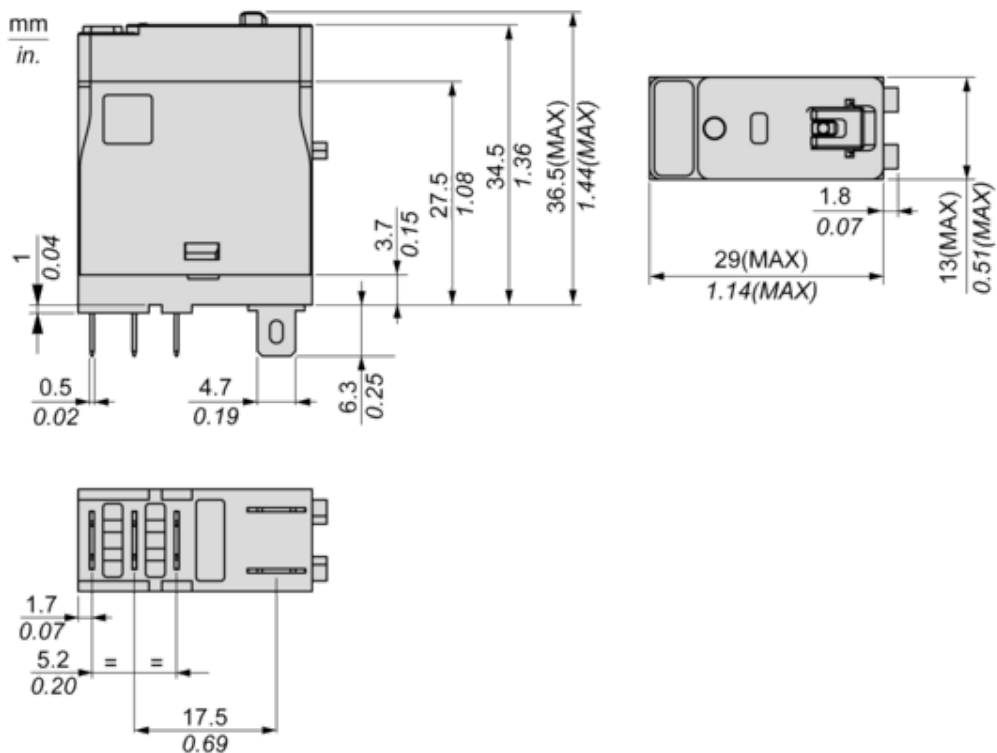

Connections and Schema

Wiring Diagram

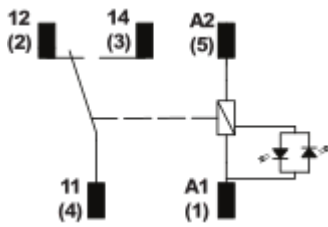

Performance Curves

Performance Curves

Maximum Switching Capacity

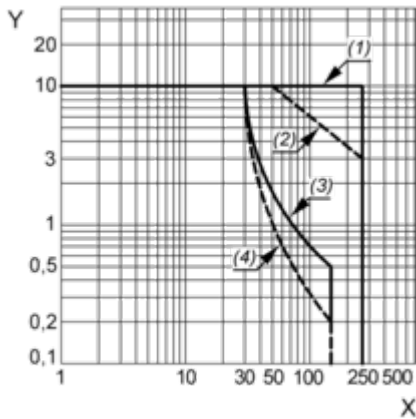

X : Switching voltage (V)

Y : Switching current (A)

(1) AC Resistive Load

(2) AC Inductive Load $\cos(\phi)=0.4$

(3) DC Resistive Load

(4) DC Inductive Load (L/R=7ms)

Life Expectancy

Resistive Load

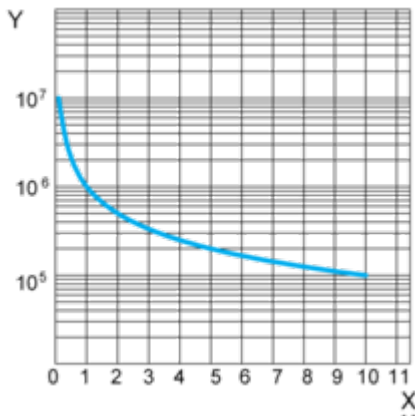

X : Contact Current (A)

Y : Operating Cycle Number

Life Expectancy

Inductive Load

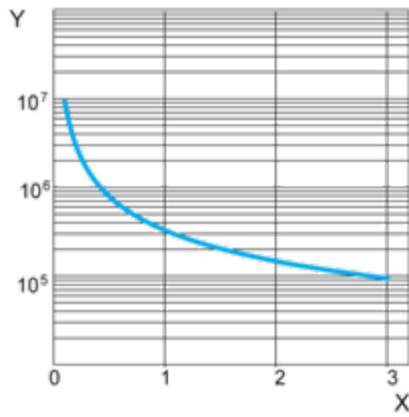

X : Contact Current (A)
Y : Operating Cycle Number

NOTE: These are typical curves, actual durability depends on load, environment, duty cycle, etc.

Coil Operating Range

DC Coil Operating Range VS Ambient Temperature

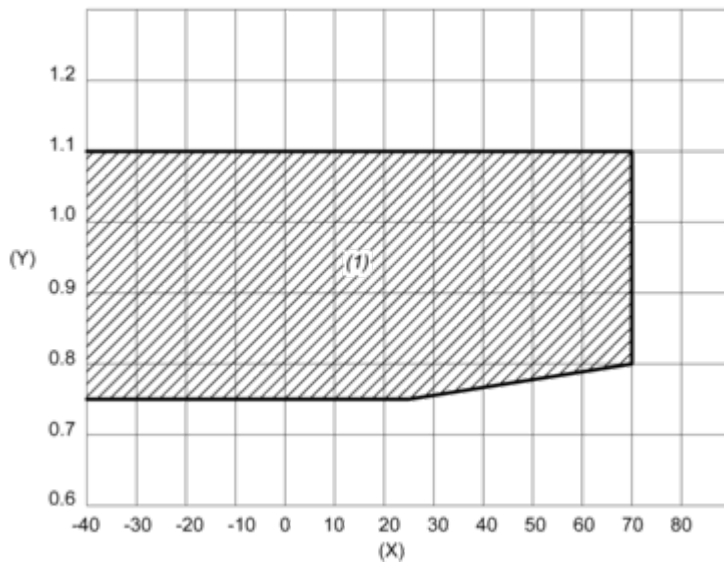

X : Ambient temperature (°C)

Y : Coil voltage (U/Uc)

(1) Permitted operating range area

Technical Illustration

Dimensions

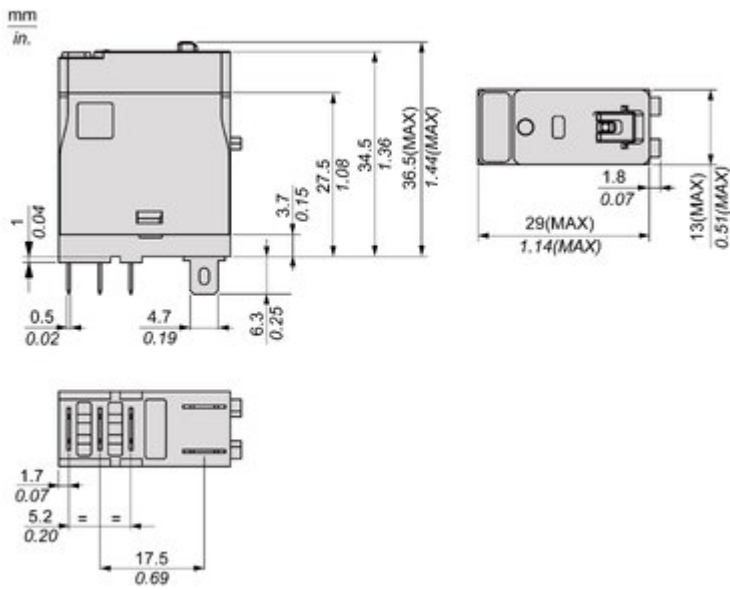
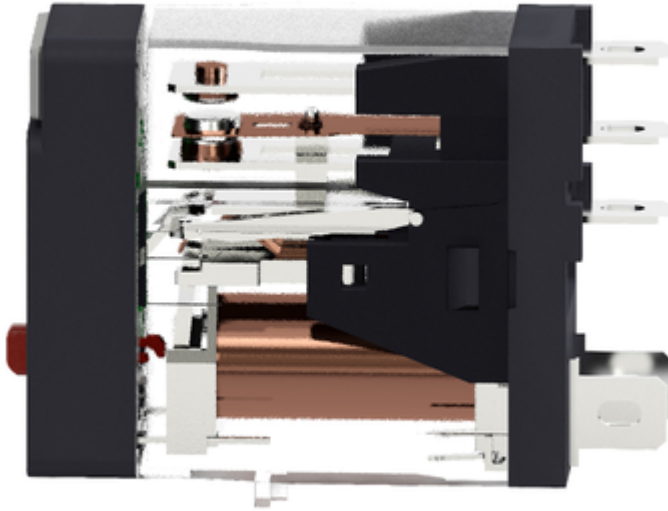

Image of product / Alternate images

Alternative





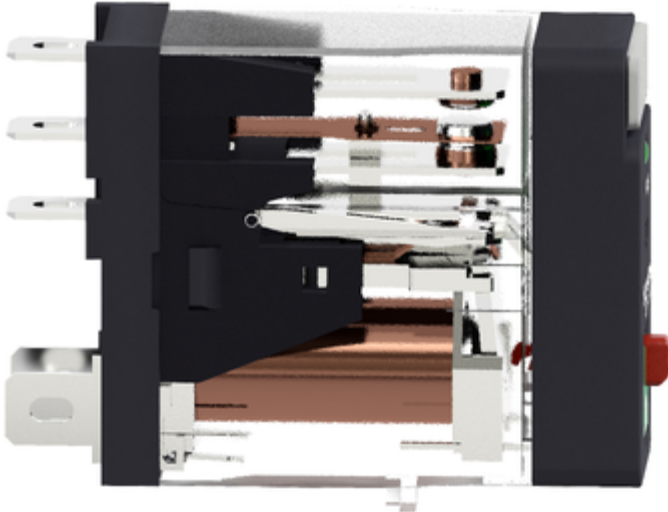

Image of product in real life situation

