

Product datasheet

Specifications



miniature plug in relay, Harmony Electromechanical Relays, 12A, 2CO, with LED, lockable test but to n, 24V DC

RXM2AB2BD

Main

Range of product	Harmony Electromechanical Relays
Series name	Miniature
Product or component type	Plug-in relay
Device short name	RXM
Contacts type and composition	2 C/O
[Uc] control circuit voltage	24 V DC
Status LED	With
Control type	Lockable test button
Utilisation coefficient	20 %

Complementary

Shape of pin	Flat
[Ui] rated insulation voltage	250 V conforming to IEC 300 V conforming to CSA 300 V conforming to UL
[Uimp] rated impulse withstand voltage	4 kV during 1.2/50 μ s
Contacts material	AgNi
[Ie] rated operational current	12 A at 28 V (DC) NO conforming to IEC 12 A at 250 V (AC) NO conforming to IEC 6 A at 28 V (DC) NC conforming to IEC 6 A at 250 V (AC) NC conforming to IEC 12 A at 28 V (DC) conforming to UL 12 A at 277 V (AC) conforming to UL
Continuous output current	10 A
Maximum switching voltage	250 V conforming to IEC
resistive rated load	12 A at 250 V AC 12 A at 28 V DC
Maximum switching capacity	3000 VA/336 W
Minimum switching capacity	170 mW at 10 mA, 17 V
Operating rate	\leq 1200 cycles/hour under load \leq 18000 cycles/hour no-load
Mechanical durability	10000000 cycles
Electrical durability	100000 cycles for resistive load
average coil consumption	0.9 W
Drop-out voltage threshold	\geq 0.1 U _c

operate time	20 ms
release time	20 ms
average coil resistance	650 Ohm at 20 °C +/- 10 %
Rated operational voltage limits	19.2...26.4 V DC
Safety reliability data	B10d = 100000
Protection category	RT I
Test levels	Level A group mounting
Operating position	Any position
Net weight	0.037 kg
Device presentation	Complete product

Environment

Dielectric strength	1300 V AC between contacts with micro disconnection 2000 V AC between coil and contact with basic insulation 2000 V AC between poles with basic insulation
Product certifications	UL Lloyd's CE CSA GOST IECEE CB Scheme
Standards	CSA C22.2 No 14 IEC 61810-1 UL 508
Ambient air temperature for storage	-40...85 °C
Ambient air temperature for operation	-40...55 °C
Vibration resistance	3 gn, amplitude = +/- 1 mm (f = 10...150 Hz)5 cycles in operation 5 gn, amplitude = +/- 1 mm (f = 10...150 Hz)5 cycles not operating
IP degree of protection	IP40 conforming to IEC 60529
Shock resistance	10 gn for in operation 30 gn for not operating
Pollution degree	3

Packing Units

Unit Type of Package 1	PCE
Number of Units in Package 1	1
Package 1 Height	2.0 cm
Package 1 Width	2.8 cm
Package 1 Length	4.8 cm
Package 1 Weight	37.0 g
Unit Type of Package 2	BB1
Number of Units in Package 2	10
Package 2 Height	3.0 cm
Package 2 Width	10.0 cm
Package 2 Length	12.5 cm
Package 2 Weight	396.0 g

Unit Type of Package 3	S02
Number of Units in Package 3	240
Package 3 Height	15.0 cm
Package 3 Width	30.0 cm
Package 3 Length	40.0 cm
Package 3 Weight	9.994 kg

Contractual warranty

Warranty	18 months
-----------------	-----------

Environmental Data

Schneider Electric aims to achieve Net Zero status by 2050 through supply chain partnerships, lower impact materials, and circularity via our ongoing “Use Better, Use Longer, Use Again” campaign to extend product lifetimes and recyclability.

[Environmental Data explained >](#)

[How we assess product sustainability >](#)

Environmental footprint

Carbon footprint (kg.eq.CO2 per CR, Total Life cycle)	35
---	----

Environmental Disclosure	Product Environmental Profile
--------------------------	---

Use Better

Materials and Substances

Packaging made with recycled cardboard	Yes
--	-----

Packaging without single use plastic	Yes
--------------------------------------	-----

EU RoHS Directive	Pro-active compliance (Product out of EU RoHS legal scope)
-----------------------------------	--

REACH Regulation	REACH Declaration
------------------	-----------------------------------

China RoHS Regulation	China RoHS declaration
-----------------------	--

Use Again

Repack and remanufacture

Circularity Profile	End of Life Information
---------------------	---

WEEE



The product must be disposed on European Union markets following specific waste collection and never end up in rubbish bins

Take-back

No

Dimensions Drawings

Dimensions

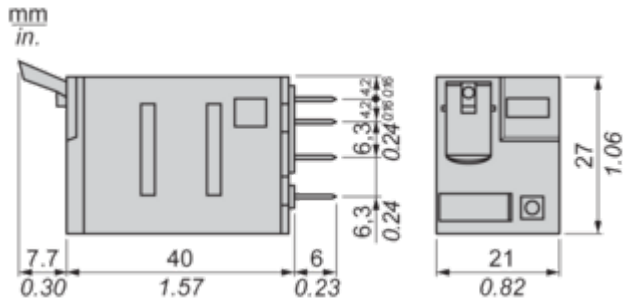

Pin Side View

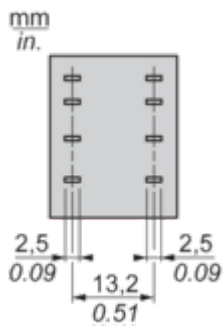

Connections and Schema

Wiring Diagram

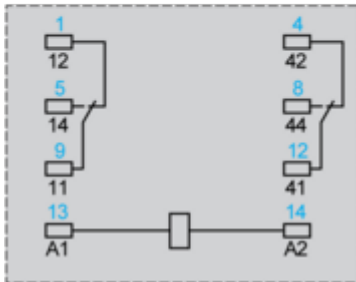
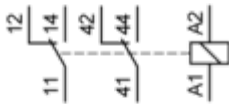

Symbols shown in blue correspond to Nema marking.

Performance Curves

Electrical Durability of Contacts

Durability (inductive load) = durability (resistive load) x reduction coefficient.

Resistive AC load

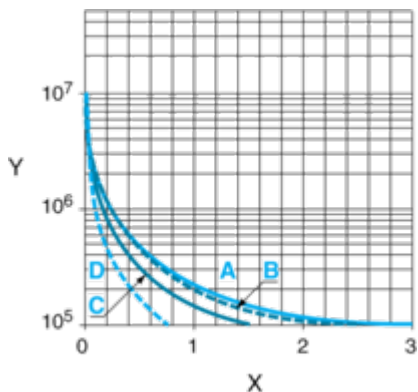

X Switching capacity (kVA)

Y Durability (Number of operating cycles)

A RXM2AB...

B RXM3AB...

C RXM4AB...

D RXM4GB...

Reduction coefficient for inductive AC load (depending on power factor cos φ)

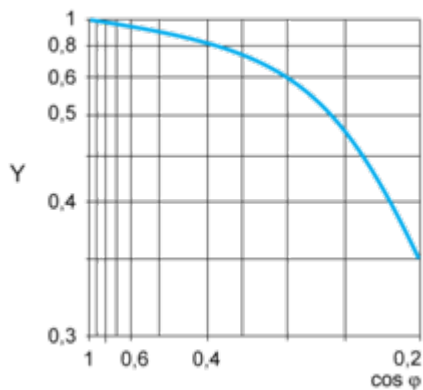

Y Reduction coefficient (A)

Maximum switching capacity on resistive DC load

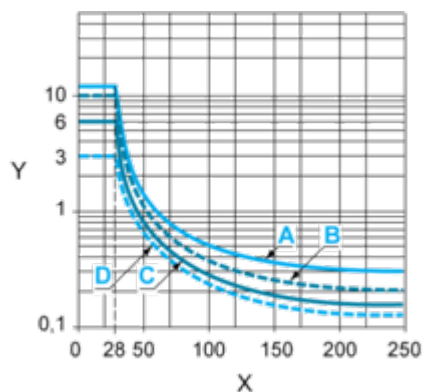

X Voltage DC

Y Current DC

A RXM2AB...

B RXM3AB...

C RXM4AB...

D RXM4GB...

Note : These are typical curves, actual durability depends on load, environment, duty cycle, etc.

For inductive load, to increase relay life cycles, please add a proper load protection circuit (eg: RC protection/Varistor/free Wheeling diode -DC load only-).

For low level loads (below 10mA), we recommend to use RXM*GB series with bifurcated contacts relays instead.

Coil Operating Range

DC Coil Operating Range VS Ambient Temperature

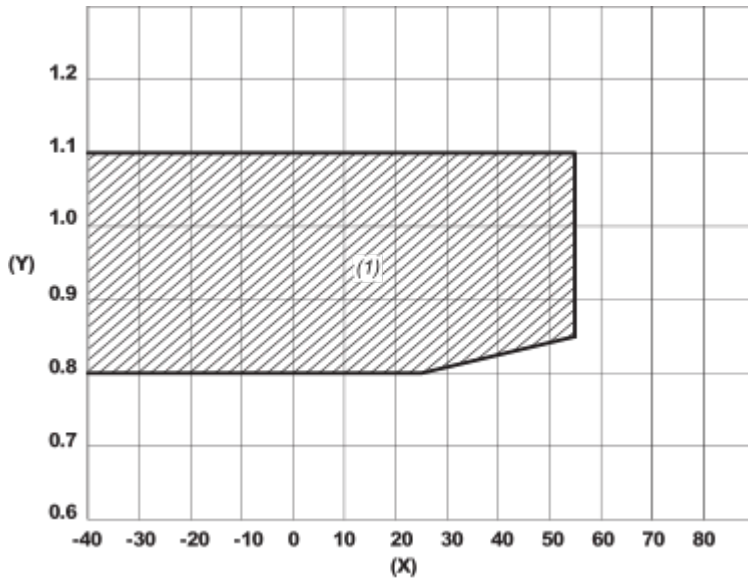

X : Ambient temperature (°C)

Y : AC coil voltage (U/Uc)

(1) Permitted operating range area

Technical Illustration

Dimensions

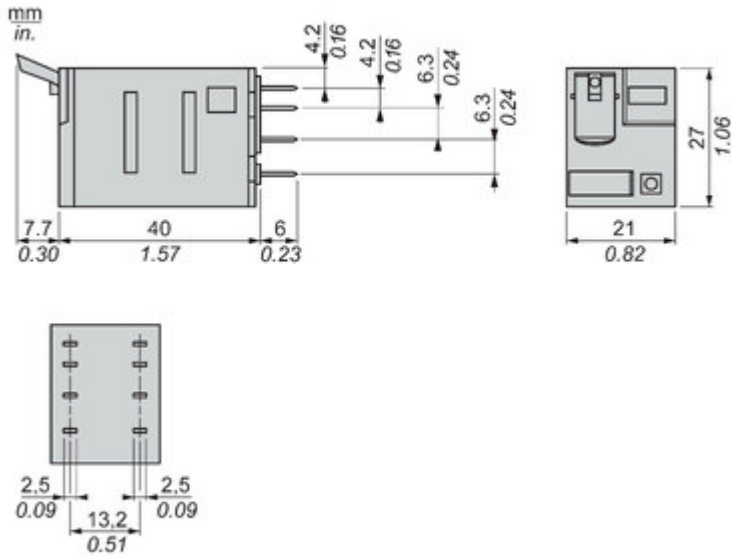
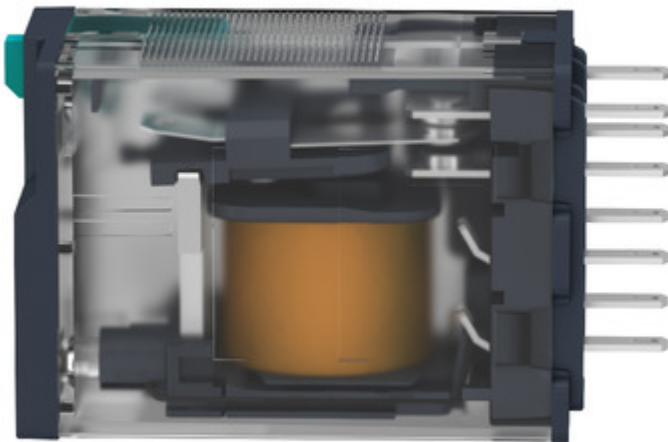
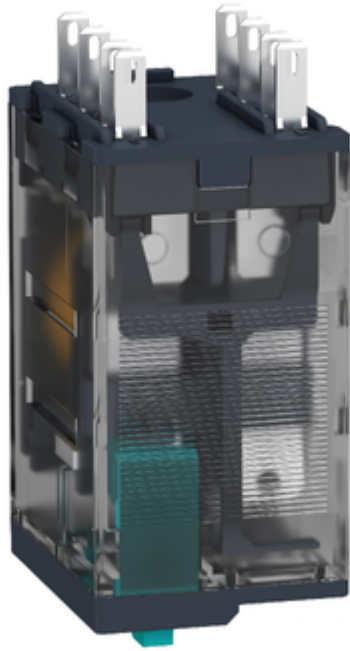

Image of product / Alternate images

Alternative



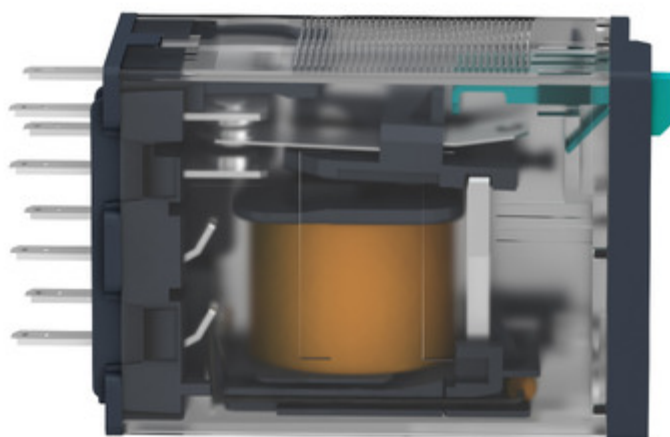



Image of product in real life situation

