

Data Sheet :

DSL302



Intertek



Electrical & Lighting Products

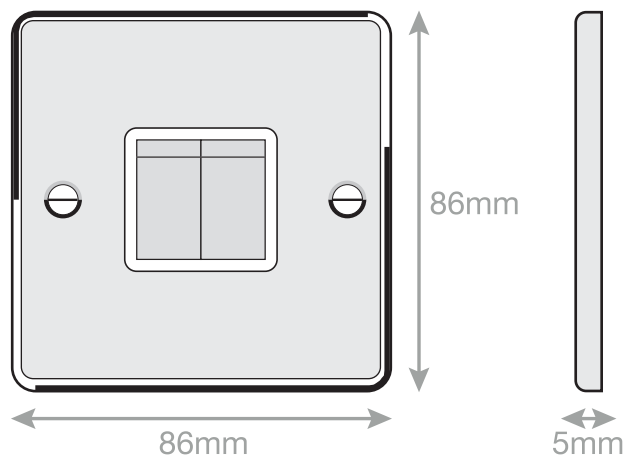
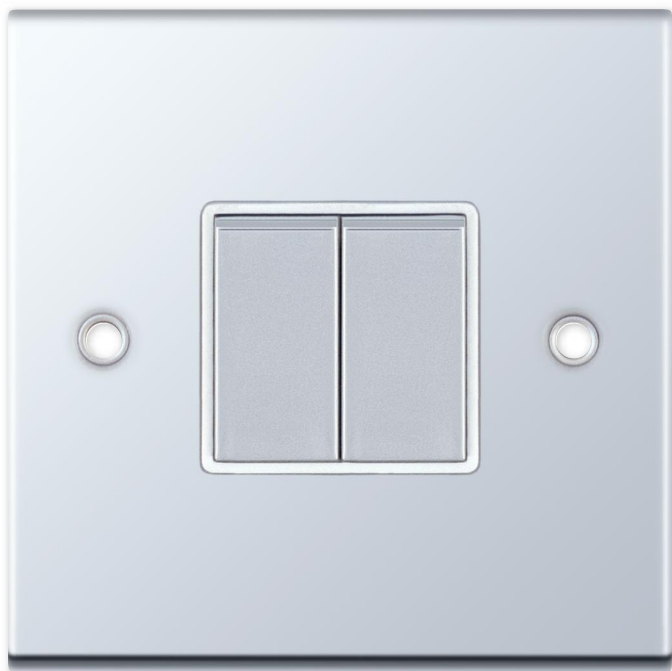

Code	DSL302
Description	10 Amp Plate Switch - 2 gang 2 way - X-Rated
Size	86mm x 86mm x 5mm depth
Range	Selectric 5M
Colour	Polished chrome white insert & matching metal rockers
Material	Premium grade steel
Included	M3.5 fixing screws & wiring instructions
Weight	0.14kg
Inner Carton Quantity	10
Inner Carton Weight	1.4kg
Guarantee	5 year plate guarantee
Barcode	5025117983027
Commodity Code	85369085
Standards	BS EN 60669-1
Notes	<ul style="list-style-type: none"> • 10 Amp plate switch modules are interchangeable with any plate product within the 5M range • ASTA approved • Each terminal capable of accepting 3 x 1.5mm • X-rated for fluorescent or inductive loads • Minimum backing box depth required: 16mm