

# Data Sheet :

## LG202



Intertek



Electrical & Lighting Products

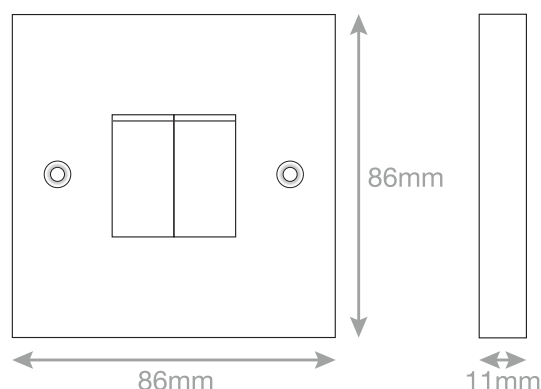

<b>Code</b>	LG202
<b>Description</b>	10 amp plate switch - 2 gang 2 way X-Rated
<b>Size</b>	86mm x 86mm (1 gang)
<b>Range</b>	Selectric Square
<b>Colour</b>	White
<b>Material</b>	
<b>Included</b>	M3.5 fixing screws
<b>Weight</b>	0.08kg
<b>Inner Carton Quantity</b>	10
<b>Inner Carton Weight</b>	0.8kg
<b>Outer Carton Quantity</b>	
<b>Outer Carton Weight</b>	
<b>Outer Carton Length</b>	
<b>Outer Carton Width</b>	
<b>Outer Carton Height</b>	
<b>Outer Carton Volume</b>	
<b>Guarantee</b>	25 years
<b>Barcode</b>	5025117998496
<b>Commodity Code</b>	85369085
<b>Standards</b>	BSEN60669-1
<b>Notes</b>	<ul style="list-style-type: none"><li>• All 10 amp plate switch modules are interchangeable with any plate product within the Square range</li><li>• ASTA Approved</li></ul>