

Data Sheet : SSL529



Intertek



Electrical & Lighting Products

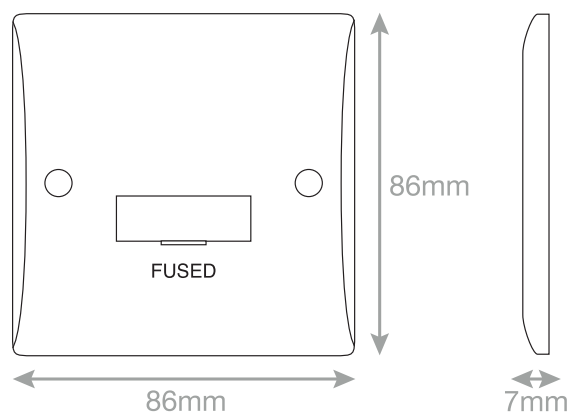

Code	SSL529
Description	13 amp fused connection unit (unswitched)
Size	86mm x 86mm (1 gang)
Range	Selectric Smooth
Colour	White
Material	Bakelite
Included	M3.5 fixing screws & white blanking caps
Weight	0.11kg
Inner Carton Quantity	10
Inner Carton Weight	1.1kg
Guarantee	30 years
Barcode	5025117986295
Commodity Code	85369085
Standards	BS 1363-4
Notes	<ul style="list-style-type: none"> • A Fused Spur or Connection Unit is commonly used for powerful electrical appliances, such as washing machines, dish washers, extractor fans, hand dryers etc, that need to be installed without a plug. They are also used for electrical items that need to be installed on a separate cable from the ring main, for safety and maintenance purposes. • ASTA approved • Minimum back box depth - 25mm