



Main

Commercial Status	Commercialised
Range of product	Harmony XALD
Product or component type	Complete control station
Device short name	XALD
Product destination	For XB5 Ø 22 mm control and signalling units
Control station application	Three functions
Colour of base of enclosure	Light grey RAL 7035
Colour of cover	Dark grey RAL 7016
Material	Polycarbonate
Operator profile	3 flush pushbuttons
Operators description	White "up arrow" 1 NO - red "O" 1 NC - black "down arrow" 1 NO
Control station composition	1 flush push-button white 1 NO black up arrow marking 1 flush push-button red 1 NC O marking 1 flush push-button black 1 NO white down arrow marking
Marking location	Marking on pushbutton
Contacts operation	Slow-break

Complementary

Cable entry	2 knock-outs for Pg 13 cable gland and ISO M20, clamping capacity: <= 12 mm 2 knock-outs for cable entry, clamping capacity: <= 14 mm
Product weight	0.298 kg
Resistance to high pressure washer	7000000 Pa at 55 °C, distance: 0.1 m
Colour of marking	Black marking when white caps White marking when green, red or black caps
Positive opening	With conforming to EN/IEC 60947-5-1 appendix K
Operating travel	4.3 mm (total travel) 2.6 mm (NO changing electrical state) 1.5 mm (NC changing electrical state)
Operating force	3.8 N (NO changing electrical state) 3.5 N (NC changing electrical state)
Mechanical durability	5000000 cycles
Connections - terminals	Screw clamp terminals : >= 1 x 0.22 mm ² without cable end conforming to EN/IEC 60947-1 Screw clamp terminals : <= 2 x 1.5 mm ² with cable end conforming to EN/IEC 60947-1
Tightening torque	0.8...1.2 N.m conforming to EN/IEC 60947-1
Shape of screw head	Slotted, flat Ø 5.5 mm Slotted, flat Ø 4 mm Cross, pozidriv No 1 Cross, Philips no 1
Contacts material	Silver alloy (Ag/Ni)
Short circuit protection	10 A by gG cartridge fuse conforming to EN/IEC 60947-5-1
[I _{th}] conventional free air thermal current	10 A conforming to EN/IEC 60947-5-1
[U _i] rated insulation voltage	600 V (degree of pollution: 3) conforming to EN/IEC 60947-1
[U _{imp}] rated impulse withstand voltage	6 kV conforming to EN/IEC 60947-1

The information provided in this documentation contains general descriptions and/or technical characteristics of the performance of the products contained herein. This documentation is not intended as a substitute for and is not to be used for determining suitability or reliability of these products for specific user applications. It is the duty of any such user or integrator to perform the appropriate and complete risk analysis, evaluation and testing of the products with respect to the relevant specific application or use thereof. Neither Schneider Electric Industries SAS nor any of its affiliates or subsidiaries shall be responsible or liable for misuse of the information contained herein.

[Ie] rated operational current	DC-13, Q600: Ue = 600 V Ie = 0.1 A conforming to EN/IEC 60947-5-1 DC-13, Q600: Ue = 250 V Ie = 0.27 A conforming to EN/IEC 60947-5-1 DC-13, Q600: Ue = 125 V Ie = 0.55 A conforming to EN/IEC 60947-5-1 AC-15, A600: Ue = 600 V Ie = 1.2 A conforming to EN/IEC 60947-5-1 AC-15, A600: Ue = 240 V Ie = 3 A conforming to EN/IEC 60947-5-1 AC-15, A600: Ue = 120 V Ie = 6 A conforming to EN/IEC 60947-5-1
Electrical durability	1000000 cycles DC-13, 0.5 A at 24 V, operating rate: 3600 cyc/h, load factor: 0.5 conforming to EN/IEC 60947-5-1 appendix C 1000000 cycles DC-13, 0.2 A at 110 V, operating rate: 3600 cyc/h, load factor: 0.5 conforming to EN/IEC 60947-5-1 appendix C 1000000 cycles AC-15, 4 A at 24 V, operating rate: 3600 cyc/h, load factor: 0.5 conforming to EN/IEC 60947-5-1 appendix C 1000000 cycles AC-15, 3 A at 120 V, operating rate: 3600 cyc/h, load factor: 0.5 conforming to EN/IEC 60947-5-1 appendix C 1000000 cycles AC-15, 2 A at 230 V, operating rate: 3600 cyc/h, load factor: 0.5 conforming to EN/IEC 60947-5-1 appendix C
Electrical reliability IEC 60947-5-4	$\Lambda < 10\exp(-8)$ at 17 V, 5 mA conforming to EN/IEC 60947-5-4 $\Lambda < 10\exp(-6)$ at 5 V, 1 mA conforming to EN/IEC 60947-5-4

Environment

Protective treatment	TH
Ambient air temperature for storage	-40...70 °C
Ambient air temperature for operation	-25...70 °C
Class of protection against electric shock	Class II conforming to IEC 60536
IP degree of protection	IP66 conforming to IEC 60529
NEMA degree of protection	NEMA 4X NEMA 13
IK degree of protection	IK03 conforming to EN 50102
Standards	EN/IEC 60947-1 EN/IEC 60947-5-1 EN/IEC 60947-5-4 EN/IEC 60947-5-5 JIS C 4520 UL 508 CSA C22.2 No 14
Product certifications	CSA UL listed
Vibration resistance	5 gn (12...500 Hz) conforming to IEC 60068-2-6
Shock resistance	50 gn (duration = 11 ms) for half sine wave acceleration conforming to IEC 60068-2-27 30 gn (duration = 18 ms) for half sine wave acceleration conforming to IEC 60068-2-27

Dimensions

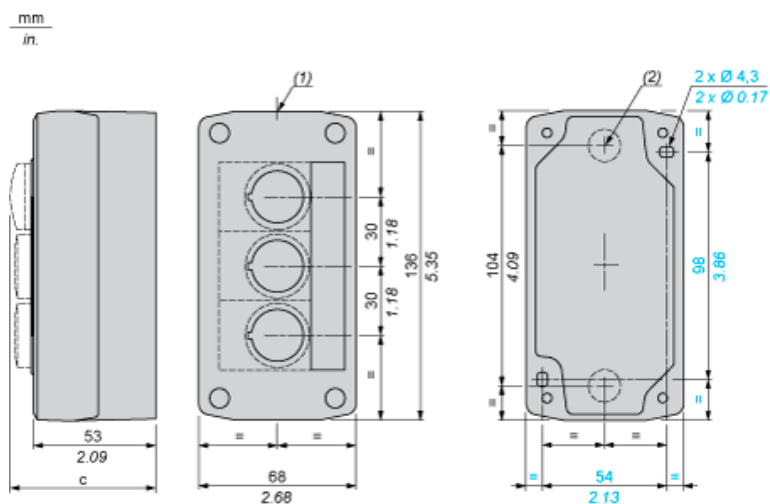

- (1) 2 knock-outs for Pg 13.5 cable gland, maximum capacity 12 mm/0.47 in.
 (2) Knock-out for cable entry, maximum capacity 14 mm/0.55 in.

Control station fitted with:	c in mm	c in in.
Flush pushbutton	62	2.44
Illuminated pushbutton	64	2.52
Pilot light	65.5	2.58
Projecting pushbutton	66	2.60
Selector switch	80	3.15
Key switch	105.5	4.15