

Lo-Carbon Quadra

Surface mountable Centrifugal Fan

Installation and Wiring Instructions



Stock Ref. N°

Quadra TP	439251B
Quadra TM	439253B
Quadra HTP	439181B

220-240V~50Hz

Vent-Axia®

PLEASE READ INSTRUCTIONS IN CONJUNCTION WITH ILLUSTRATIONS. PLEASE SAVE THESE INSTRUCTIONS.

IPX4



Technical Specifications (Tested at 240 VAC @ 50Hz):

- Air Performance: 6, 9, 12, 15, 30 or 60 l/s (22, 32, 43, 54, 108 or 216 m³/h).
- Power consumption: 3 - 45W.
- Exhaust spigot diameter: Ø100mm.
- Installed size: 260 x 230 x 112 mm

Features:

- Surface mountable.
- Optional Filter available as an accessory (439927).
- Option to boost from constant trickle or from off.
- Three trickle speed options available, selectable during installation (6, 9 or 12 l/s).
- Three boost speed options available, selectable during installation (15, 30 or 60 l/s).
- LS connection (remote switch can switch the fan from the off or trickle state to boost).
- Adjustable timer overrun (1-30 minutes approximately).
- Variable speed boost for humidity models.

Model Specific Methods to Select Boost Speed:

	TP	TM	HTP
<input type="checkbox"/> Pullcord	✓		✓
<input type="checkbox"/> Movement sensor (P.I.R)		✓	
<input type="checkbox"/> Adjustable relative humidity sensor			✓

INSTALLATION AND WIRING INSTRUCTIONS



**IMPORTANT:
READ THESE INSTRUCTIONS BEFORE COMMENCING THE INSTALLATION**

DO NOT install this product in areas where the following may be present or occur:

- Excessive oil or a grease laden atmosphere.
- Corrosive or flammable gases, liquids or vapours.
- Ambient temperatures higher than 40°C or less than -5°C.
- Possible obstructions which would hinder the access or removal of the Fan.

SAFETY AND GUIDANCE NOTES

- A.** All wiring to be in accordance with the current I.E.E. Regulations, or the appropriate standards of your country and **MUST** be installed by a suitably qualified person.
- B.** The Fan should be provided with a local isolator switch capable of disconnecting all poles, having a contact separation of at least 3mm.
- C.** Ensure that the mains supply (Voltage, Frequency, and Phase) complies with the rating label.
- D.** The Fan should only be used in conjunction with the appropriate Vent-Axia products.
- E.** It is recommended that the connection to the fan connector terminals is made with flexible cable.
- F.** When the Fan is used to remove air from a room containing a fuel-burning appliance, ensure that the air replacement is adequate for both the fan and the fuel-burning appliance.
- G.** The Fan should not be used where it is liable to be subject to direct water spray for prolonged periods of time.
- H.** Where ducted Fans are used to handle moisture-laden air, a condensation trap should be fitted. Horizontal ducts should be arranged to slope slightly downwards away from the Fan.
- I.** This appliance is not intended for use by persons (including children) with reduced physical, sensory or mental capabilities, or lack of experience and knowledge, unless they have been given supervision or instruction concerning use of the appliance by a person responsible for their safety.
- J.** Children should be supervised to ensure that they do not play with the appliance.

DESCRIPTION

As standard, the Quadra is suitable for panel/ceiling or wall installations (For surface mounting only) either in a horizontal or vertical plane. Ø100mm ducting (flexible or rigid) can be attached providing rear exit. Adaptors for rectangular ducting can also be used. For wall installations a Wall Kit (25 41 02 White / 25 41 00 Brown) can be used. Please see our catalogue or web site (www.vent-axia.com) for more information on alternative ducting and termination options. A Filter (439927) is available as an accessory.

A. INSTALLATION

A Backdraught Shutter Assembly is supplied. It is packed inside the product during transport. It is designed to block the duct when the fan is off in order to prevent cold draughts from outside entering the building. If you are going to set the fan up to extract air continuously (constant trickle), you do not necessarily need it. To use it, push it on to the end of the exhaust Spigot with the hinges on the flaps vertical (*fig. 1*).

IMPORTANT: Be careful to avoid joists and hidden pipes or cables when cutting or drilling holes.

SURFACE MOUNTING (PANEL/CEILING)

1. Remove the Front Cover Assembly by slackening the 2 Cover Screws by 2 turns (*fig.2.*) Lift the Cover Assembly away from the bottom edge then the top edge.
2. Cut a $\varnothing 105\text{mm}$ hole and suitable screw holes in the panel, ensuring that there is sufficient space for the product to be installed and that the optional Filter (*fig.3*) could be removed for cleaning. The cardboard fitment in the packaging can be used as a template.
3. Set-up the appropriate speed selection and other features as outlined in **Section B SETUP.**
4. Remove the Internal Covers that cover the Terminal Block and PCB area (*fig.4*).
5. Attach the ducting to the Spigot and locate the Fan into the hole in the panel. Feed wiring through the hole in the Chassis next to the Terminal Block as you do so. (*fig. 4*)
6. Secure into position using appropriate screws and rawl plugs.
7. Select and follow the appropriate wiring diagram in **Section C WIRING.**
8. Replace the Internal Covers.
9. Ensure the Impeller rotates freely.
10. Replace the Front Cover Assembly and tighten the two screws.
11. Switch the mains power supply on and check the fan is operating correctly.

SURFACE MOUNTING (WALL)

For through-the-wall installations, a Wall Kit (25 41 02 White / 25 41 00 Brown) can be used.

1. Remove the Front Cover Assembly by slackening the 2 Cover Screws by 2 turns (*fig.2.*) Lift the front assembly away from the bottom edge then the top edge.
2. Cut a $\varnothing 117\text{mm}$ hole through the wall, ensuring that there is sufficient space for the product to be installed and that the optional Filter (*fig.3*) can be removed for maintenance. The cardboard fitment inside the packaging can be used as a template.
3. Insert the wall sleeve with the larger diameter sleeve on the room-side and cement the ends into position flush with the wall faces. The wall sleeve should be angled downwards, away from the Fan, to allow any condensation to drain to outside.
4. Outside Grille (available separately): Using the Grille's Back Plate as a template, mark the fixing hole centres on the wall. Drill and plug the wall and fix the Grille into position. Ensure the louvres are pointing downwards.
5. Set-up the appropriate speed selection and other features as outlined in **Section B SETUP.**
6. Remove the Internal Covers that cover the Terminal Block and PCB area (*fig 4*).
7. Using the Fan Chassis as a template, carefully sliding the spigot into the Wall Liner, mark the fixing hole centres on the wall.
8. Drill and plug the wall using the fixings provided.
9. Feed the wiring through the hole near the Terminal Block (*fig.4*) and secure the Fan into position using the screws provided.
10. Select and follow the appropriate wiring diagram in **Section C WIRING.**
11. Replace the Internal Covers.
12. Ensure the Impeller (*fig.3*) rotates freely.
13. Replace the Front Cover Assembly and tighten the two screws.
14. Switch the mains power supply on and check the fan is operating correctly

B. SETUP



WARNING: THE FAN AND ANCILLARY CONTROL EQUIPMENT MUST BE ISOLATED FROM THE POWER SUPPLY DURING INSTALLATION OR MAINTENANCE.



IMPORTANT

On first power up, the fan will run through its initialization routine.
On **TP**, **HTP** & **TM** models the fan will switch on and off during this routine (Including the LED)
Once complete after approximately 2 minutes, the fan will run as normal.

With the Cover removed the humidity adjustment, overrun timer adjustment, speed selection switches and installation type switches are accessible in the bottom right corner of the product (*figs.4 & 5*).

1. SELECTING THE CONSTANT TRICKLE SPEED (0, 6, 9 or 12 l/s)

This will determine the speed at which the fan will run most of the time except when boost is activated by either the Pullcord, PIR, LS, or Relative Humidity Sensor.

- i. Slide one of the three switches marked as 'Normal/Trickle Speed' in *fig.5* to the right (on position) to select that flow rate for trickle speed.
- ii. Setting all of those 3 switches to the left (off positions) will switch off the constant trickle option (i.e the fan will normally be off and will switch to boost when the Pullcord, PIR, LS or Humidity Sensor are activated).

2. SELECTING THE BOOST SPEED (15, 30 or 60 l/s)

This will determine the speed at which the fan will run when activated by either the Pullcord, PIR, LS, or Relative Humidity Sensor (note: the %RH boost speed is 50% of the set boost flow rate – see *Relative Humidity Adjustment* section below).

- i. Slide one of the three switches marked as 'Boost Speed' in *fig.5* to the right (on position) to select that flow rate for boost speed.

3. TIMER ADJUSTMENT

The overrun time period is the length of time that the fan will continue to run at boost for after the LS connection is switched off or the PIR (Quadra TM only) stops sensing movement. It is factory set to approximately 15 minutes. The overrun time period may be adjusted from approximately 1-30 mins by altering the adjuster on the control PCB. (*figs.4 & 5*).

- i. To REDUCE the operating time, turn the adjuster ANTI-CLOCKWISE.
- ii. To INCREASE the operating time, turn the adjuster CLOCKWISE.

4. RELATIVE HUMIDITY ADJUSTMENT (HTP model only)

The fan's Relative Humidity (RH) Set-Point is factory set to switch the fan on at about 72%RH. The fan will increase the flow rate proportionally with %RH to 50% of the set boost speed. If constant trickle is selected, the fan will increase the flow rate from the set trickle rate to 50% of the boost rate.

- i. To LOWER the Set-Point, turn the Humidity Adjuster (*figs.4 & 5*) ANTI-CLOCKWISE. This makes the fan more sensitive to RH%, i.e. the fan will come on at a lower RH%.
- ii. To RAISE the Set-Point, turn the Humidity Adjuster (*figs.4 & 5*) CLOCKWISE. This makes the fan less sensitive to RH%, i.e. the fan will come on at a higher RH%.

C. WIRING.



WARNING: THE FAN AND ANCILLARY CONTROL EQUIPMENT MUST BE ISOLATED FROM THE POWER SUPPLY DURING INSTALLATION OR MAINTENANCE.

Use 0.75mm² cable

1. Select and follow the appropriate wiring diagram (*figs. 7 & 8*).
2. Additional controls, such as room mounted humidistats, pullcords, PIR sensors and normal/boost switches, can be connected to the LS connection instead of the room lighting circuit in fig 10 in order to make the fan boost. These accessories must switch a 240V 50Hz live connection on when boost is wanted.
3. Use the Cable Clamp and grommet provided (Fig 4).
4. Check all connections have been made correctly and ensure all terminal connections are securely fastened.

D. SERVICING AND MAINTENANCE.



WARNING: THE FAN AND ANCILLARY CONTROL EQUIPMENT MUST BE ISOLATED FROM THE POWER SUPPLY DURING SERVICING OR MAINTENANCE.

1. At intervals appropriate to the installation, the fan should be inspected and cleaned to ensure there is no build up of dirt or other deposits.
2. If you have a Filter (*fig.3*), remove it by using a small, flat bladed screwdriver to lift the bottom edge over the retaining edge (*fig.2*) and then slide the filter out.
3. Remove the Cover assembly by slackening the two cover screws (*fig.2*) by two turns and pull it away.
4. Remove the Impeller (*fig.3*) by pressing the two clips together in the middle and pulling it off the Motor.
5. Wipe the outside of the fan with a damp (not dripping wet) cloth until clean.
6. Wash the Filter, Cover Assembly and Impeller in warm, soapy water if they are dirty. Do not use abrasive cleaners. Dry the parts before replacing them.
7. Turn the power to the Fan back on.

The fan has sealed for life bearings, which do not require lubrication.

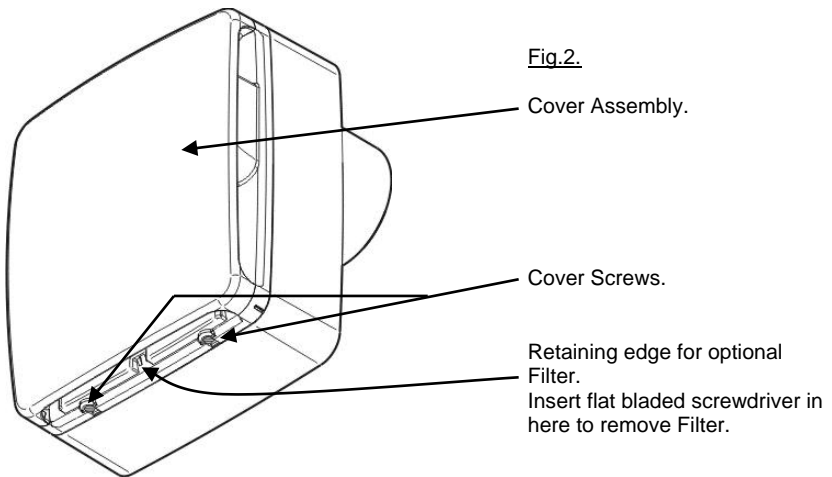
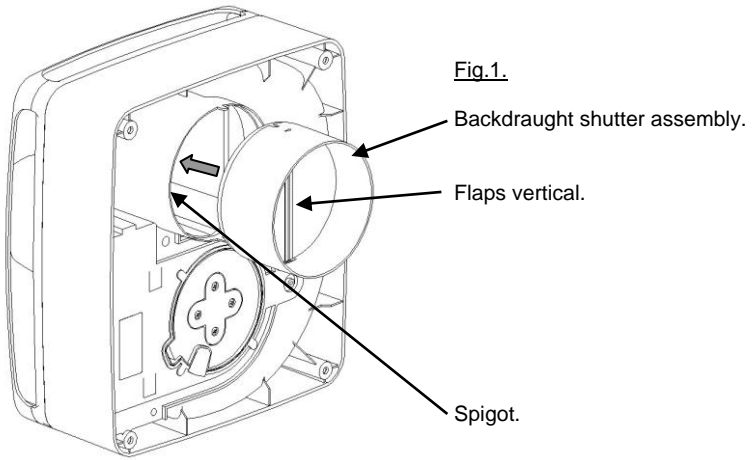

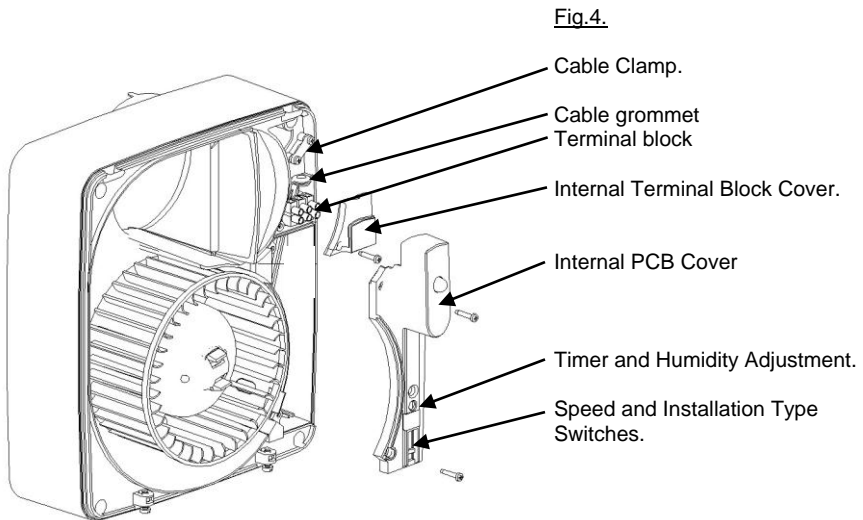
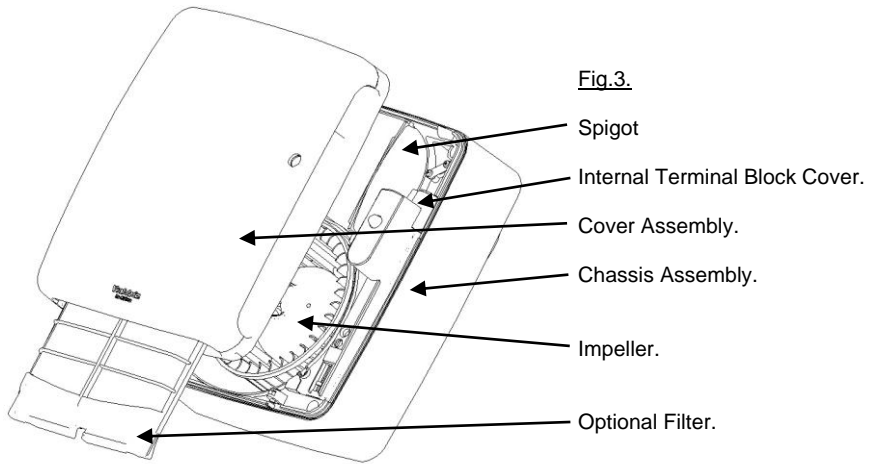

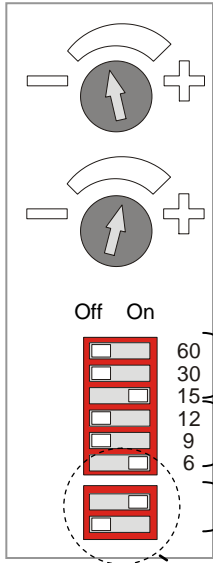

Fig.5.

Timer adjustment.
Turn clockwise to increase overrun timer.

Humidity Setpoint Adjustment.
Turn clockwise to raise set point.

Speed Selection Switches.
(Example shown is boost speed of 15 l/s and normal/trickle speed of 6 l/s.)

Installation Type Selection Switches:

← Through the wall installation.

← 1.5m Ø100mm ducting with one 90° bend and a wall grille.

← 3m Ø100mm ducting with two 90° bends and a wall grille.

Fig 6. Siting of the fan.

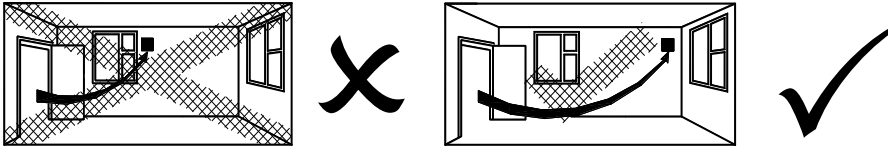

Fig 7. Wiring diagram without LS connection.

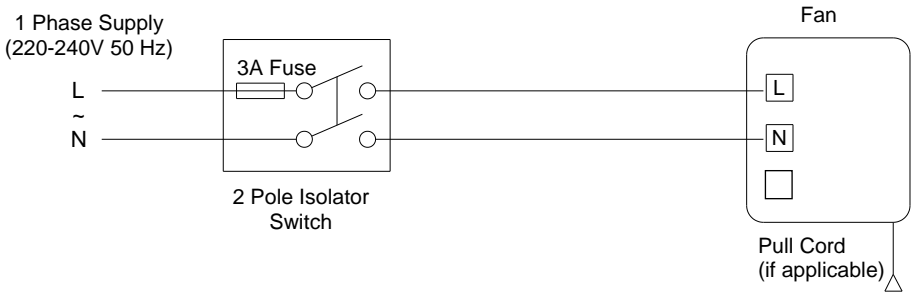
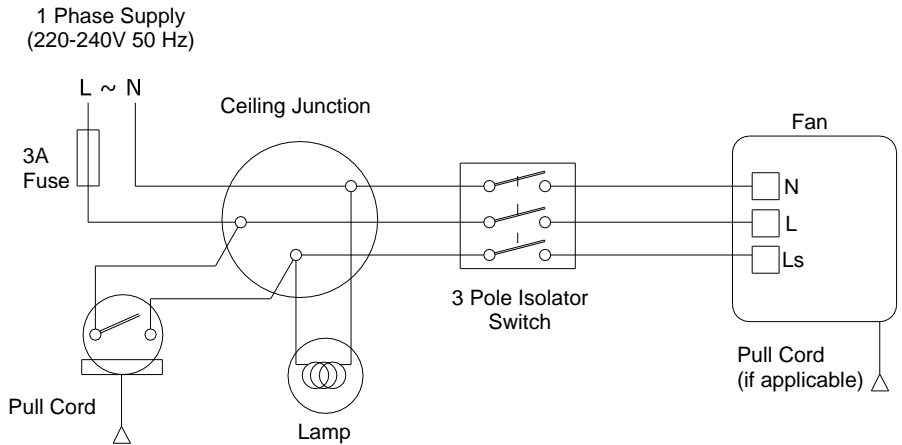

Fig 8. Wiring diagram with LS connection.



The **Vent-Axia** Guarantee

Applicable only to products installed and used in the United Kingdom. For details of guarantee outside the United Kingdom contact your local supplier.

Vent-Axia guarantees its products for two years from date of purchase against faulty material or workmanship. In the event of any part being found to be defective, the product will be repaired, or at the Company's option replaced, without charge, provided that the product:-

- Has been installed and used in accordance with the instructions given with each unit.
- Has not been connected to an unsuitable electricity supply. (The correct electricity supply voltage is shown on the product rating label attached to the unit).
- Has not been subjected to misuse, neglect or damage.
- Has not been modified or repaired by any person not authorised by the company.

IF CLAIMING UNDER TERMS OF GUARANTEE

Please return the complete product, carriage paid to your original supplier or nearest Vent-Axia Centre, by post or personal visit. Please ensure that it is adequately packed and accompanied by a letter clearly marked "Guarantee Claim" stating the nature of the fault and providing evidence of date and source of purchase.

The guarantee is offered to you as an extra benefit, and does not effect your legal rights

Vent-Axia

Head Office: Fleming Way, Crawley, West Sussex, RH10 9YX.

UK NATIONAL CALL CENTRE, Newton Road, Crawley, West Sussex, RH10 9JA

SALES ENQUIRIES:

Tel: 0844 8560590 Fax: 01293 565169

TECHNICAL SUPPORT:

Tel: 0844 8560594 Fax: 01293 539209

Web:-www.vent-axia.com

Email:- info@vent-axia.com

As part of the policy of continuous product improvement Vent-Axia reserves the right to alter specifications without notice.